

One Source

# KREBS® millMAX™ Pumps



The ORIGINAL suction side sealing pump

**FLSMIDTH**  
**KREBS**

# Don't speed up your pump!

## millMAX™ technology solves this problem!



Competitor's pump impeller eye enlarged and deformed indicating suction side recirculation.



millMAX pump impeller eye protected from recirculation wear by the wear ring.

### The millMAX™ Advantage.

The millMAX pump has a unique proprietary design developed exclusively for pumping abrasive slurries. Before the millMAX pump, slurry pumps had two major problems: mechanical grinding of solids between the suction liner and impeller, and flow recirculating back to the impeller eye on the suction side. Both of these problems decrease pump life and increase power consumption. Conventional slurry pumps can only solve one of these issues through impeller and liner adjustment, but not both.

The millMAX™ pump product family features a proprietary suction side sealing system that both eliminates the inefficient recirculation and the grinding of slurry. millMAX is the **ONLY** pump line that can do this effectively.

### Don't speed up your pump.

As slurry pumps wear out, the gap between the impeller and suction liner opens up causing slurry to recirculate rather than exit the pump through the discharge. This causes the flow and head generated by the pump to drop and operators must then speed up the pump to keep up with production. Increasing the speed of a pump causes the rate of wear of all pump components to increase exponentially. This in turn causes operators to increase the speed even more to compensate, creating a snowball effect which leads to the destruction of the pump. millMAX pumps allow operators to close the suction side gap while the pump is running, restoring pump performance **WITHOUT** speeding up the pump.

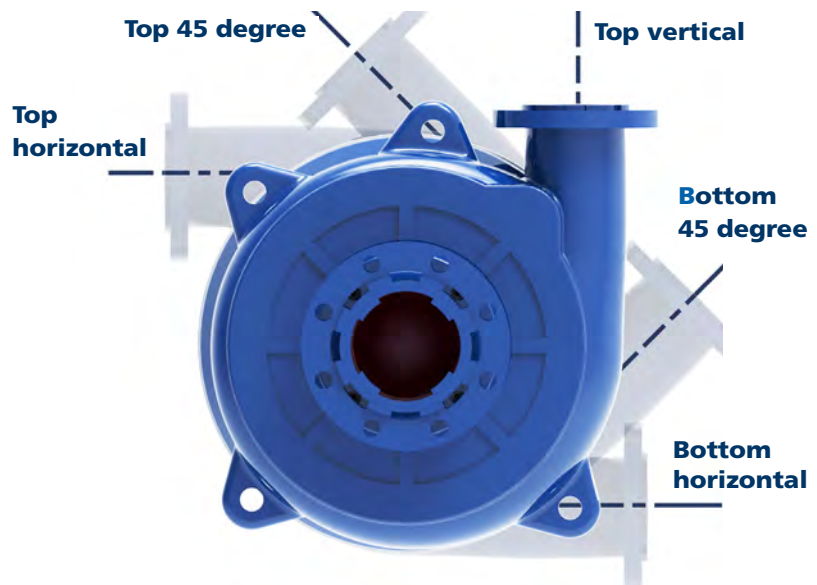

Standard millMAX discharge positions

# Grind in the mill, not in your pump!

**Grind in the mill, not in your pump.** To stop recirculation, pumps without a wear ring must adjust their impeller and suction liner close together. When pumping fluids with no solids this is effective, however, with slurries the solids get between the rotating impeller and static suction liner and are crushed. Grinding these solids consumes power and wears out the impeller and liner. Additionally, in many industries such as the diamond and potash industries, grinding of solids is not acceptable because it degrades the value of the product. millMAX pumps stop recirculation with the wear ring and allow for a large gap between the impeller and suction liner, eliminating the grinding of solids. This advantage has been proven worldwide to reduce power costs, reduce maintenance costs, and eliminate particle degradation when compared to conventional pumps.

## The millMAX™ Payoff.

Because millMAX pumps maintain a constant operating speed and they do not grind particles, they

naturally last longer and consume less power. This means less plant downtime and lost production, with less money spent on pump maintenance and power. millMAX pumps are the latest and most advanced slurry pumping technology on the market today. With a wide range of material options, pump designs, pump selections and application knowledge, FLSmidth Krebs is able to provide the highest quality and lowest total cost of ownership solutions on the market for any slurry pump application.

## Give it a try!

millMAX pump wet ends can easily adapt to competitor power frames for easy head to head comparison. Complete pump replacements are recommended when possible, as the millMAX bearing assembly design (shown on the next page) has the potential to eliminate bearing failure caused by over greasing. Bearing failure can be a major expense and hassle for conventional pump operators when it need not be.



millMAX inventor, John Frater



Gold Mine, Australia



Copper Mine, Africa



Dredging, Netherlands

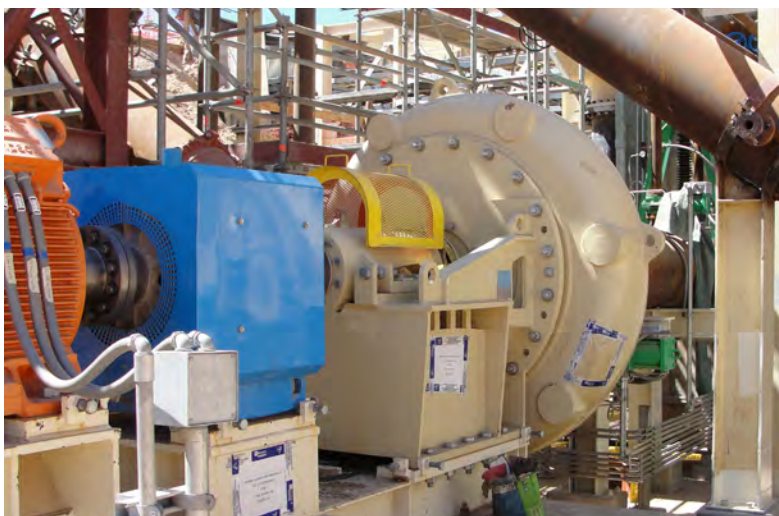

Copper, Chile

# Technical - Specifications

## The Krebs millMAX™ pump design includes the following:

**Casing** - designed for minimum slurry turbulence and even wear. Includes integral wear ring, carrier, and adjustment screws for on-line adjustment and elimination of suction side recirculation.

**Wear Ring** - adjustable wear ring assembly to permit closing of suction side impeller clearance during operation.

**Impeller** - designed for high slurry efficiency and hydraulic performance. Machined surface at the eye for wear ring adjustment and high expelling vanes.

**Suction Liner** - with integral wear ring, matching full impeller diameter and profile for close operating clearance.

**Wear Parts** - designed hydraulically to wear evenly. Constructed of high chrome iron.

**Power Frame** - heavy duty cast iron pedestal with external bearing assembly adjustment mechanism. Drilled for overhead motor mounting assembly.

**Flanges** - loose intake and discharge flanges drilled to suit various pipe requirements.

**Bearing Assembly** - heavy duty shaft and indirect fitted taper roller bearings rated at 100,000 hrs B-10 life minimum.

## millMAX™ Power Frame

- Heavy duty cast pedestal
- External bearing assembly adjustment
- Wide bearing centers
- Heavy duty shaft and bearings.
- Double clamp

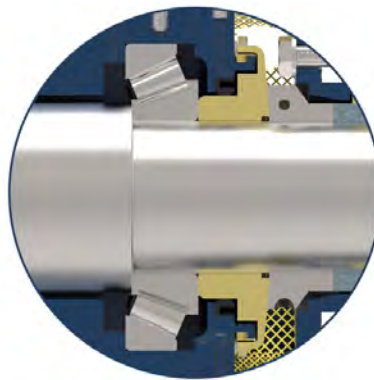

## Reverse Taper Roller Bearings

- Increases effective load span to improve life
- Pumping action of taper rollers discharges grease to the outside, preventing ingress of slurry and eliminates possibility of failure due to over greasing

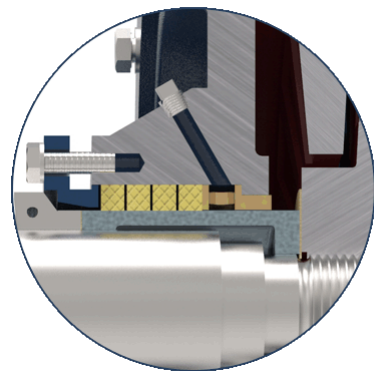

**Water Flush Full Flow Gland Seal shown. Low Flow Gland Seal not show.**

## Narrow Clearance

- Reduces pressure at gland to assist centrifugal dry gland seal or reduce gland water pressure.



## Maximum expected flow rate into a water flush seal at 10 psig (68.9 kPa) above pump discharge pressure

Power Frame	Full Flow (gpm)	Full Flow (m <sup>3</sup> /h)	Low Flow (gpm)	Low Flow (m <sup>3</sup> /h)
MMAA	8.0	1.8	1.0	0.2
MMA	15.0	3.4	2.0	0.5
MMB	20.0	4.5	3.0	0.7
MMC	25.0	5.7	4.0	0.9
MMD	30.0	6.8	5.0	1.1
MME	55.0	12.5	N/A	N/A
MMF	85.0	19.3	N/A	N/A

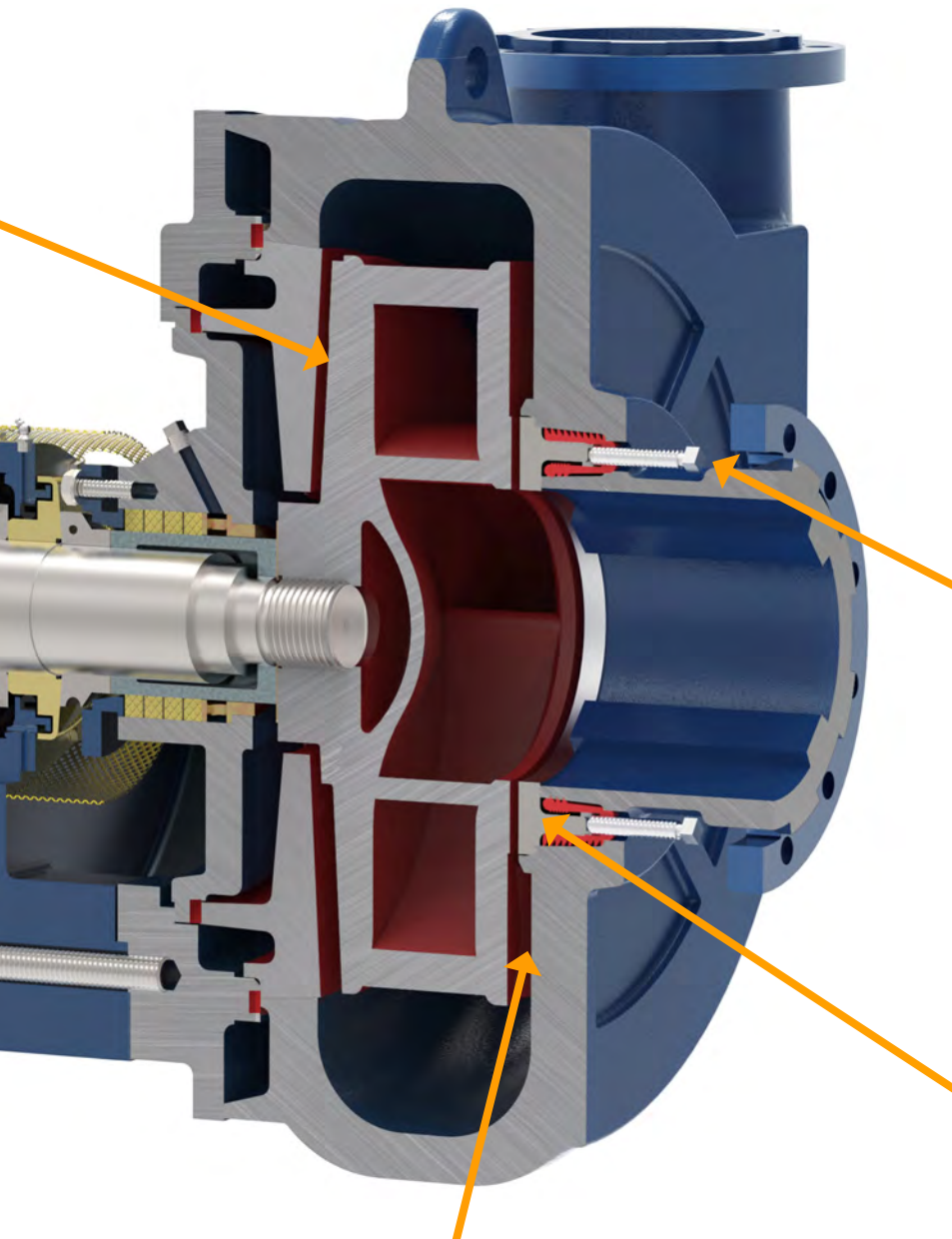

### High Radial Vanes

- Clears large solids
- Prevents solids from being crushed
- Reduces casing slurry pressure at the eye of the impeller



### External Wear Adjustment Screw

- Adjustment screws for SIMPLE & SAFE wear ring adjustment while pump is in operation.



### Adjustable Wear Ring

- Wear ring takes up clearance at the impeller
- Reduces suction side recirculation
- Maintains hydraulic performance



### Wide Clearance

- Dramatic reduction in crushing of solids
- Increased wear life
- Reduced power consumption

**Centrifugal Dry Gland Seal  
& Mechanical Seal Options Available**

# millMAX™ High Pressure Pump

The millMAX-High Pressure (HP) product line includes a tie-bolt design for high pressure multi-stage applications. millMAX tie-bolt design pumps are safe and easy to work on yet can handle over 500 PSI (35 bar) operating pressures. They have the same superior internal hydraulic design as their standard pressure millMAX counterparts.

High pressure applications produce extreme forces on the pump suction liners, making full face adjustment of traditional designs nearly impossible and unsafe. The millMAX wear ring has a small cross sectional area and has proven to be easy to adjust in the highest pressure applications.

This gives the millMAX-HP the ability to easily maintain suction side sealing throughout the life of the pump, leading to higher pumping efficiency and constant operating speeds for a given discharge head. These factors increase the wear life of the wet end components over the competition.

The tie bolt design of the millMAX-HP also allows for ultrasonic casing thickness measurements. Measuring casing thicknesses all around the pump allows operators to predict and schedule maintenance shutdowns before any failures occur. This is not possible with split casing pumps.

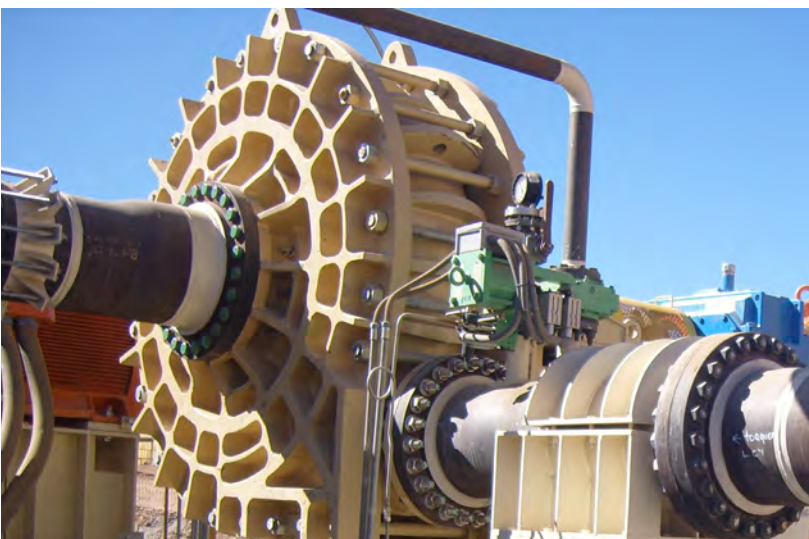

**millMAX Standard Volute Design**

# millMAX™ High Head Pump

The millMAX-High Head (HH) pump was designed for applications that have high total dynamic head requirements. The primary feature is the concentric casing that creates a uniform clearance between the casing and impeller. Standard volute slurry pumps experience radial thrust on their impellers when they operate far away from BEP due to differential pressure zones within the pump casing. This radial thrust causes shaft deflection and premature bearing and gland sealing failures. The millMAX-HH concentric casing design creates an even velocity and pressure around the casing regardless of where

the pump is in relation to BEP. millMAX-HH pump casings have a higher pressure ratings to account for high speed and multi-stage applications.

Filter press feed is one application suited for the millMAX-HH design as it includes duty requirements that range from low head and high flow, to high head and low flow. However, the millMAX-HH is suited for any application where high heads are required in one or two stage pumping systems.

## Casing pressure distribution when operating far left of BEP

millMAX-HH Concentric Volute Design

millMAX Standard Volute Design

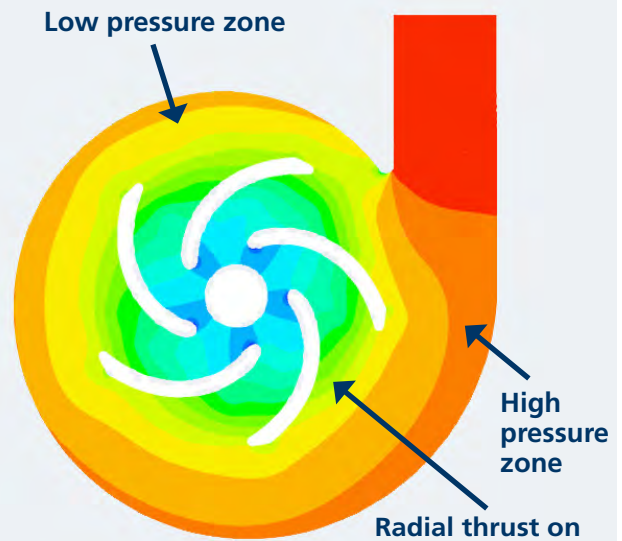
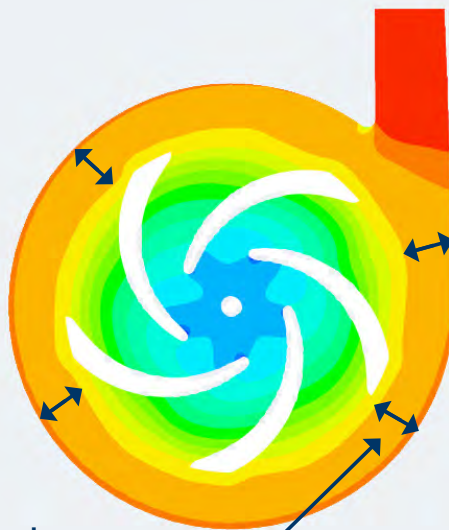
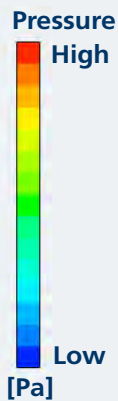

millMAX-HH Concentric Volute Design



millMAX-HH in series

# KREBS® milMAX™ Pumps

www.flsmidthkrebs.com

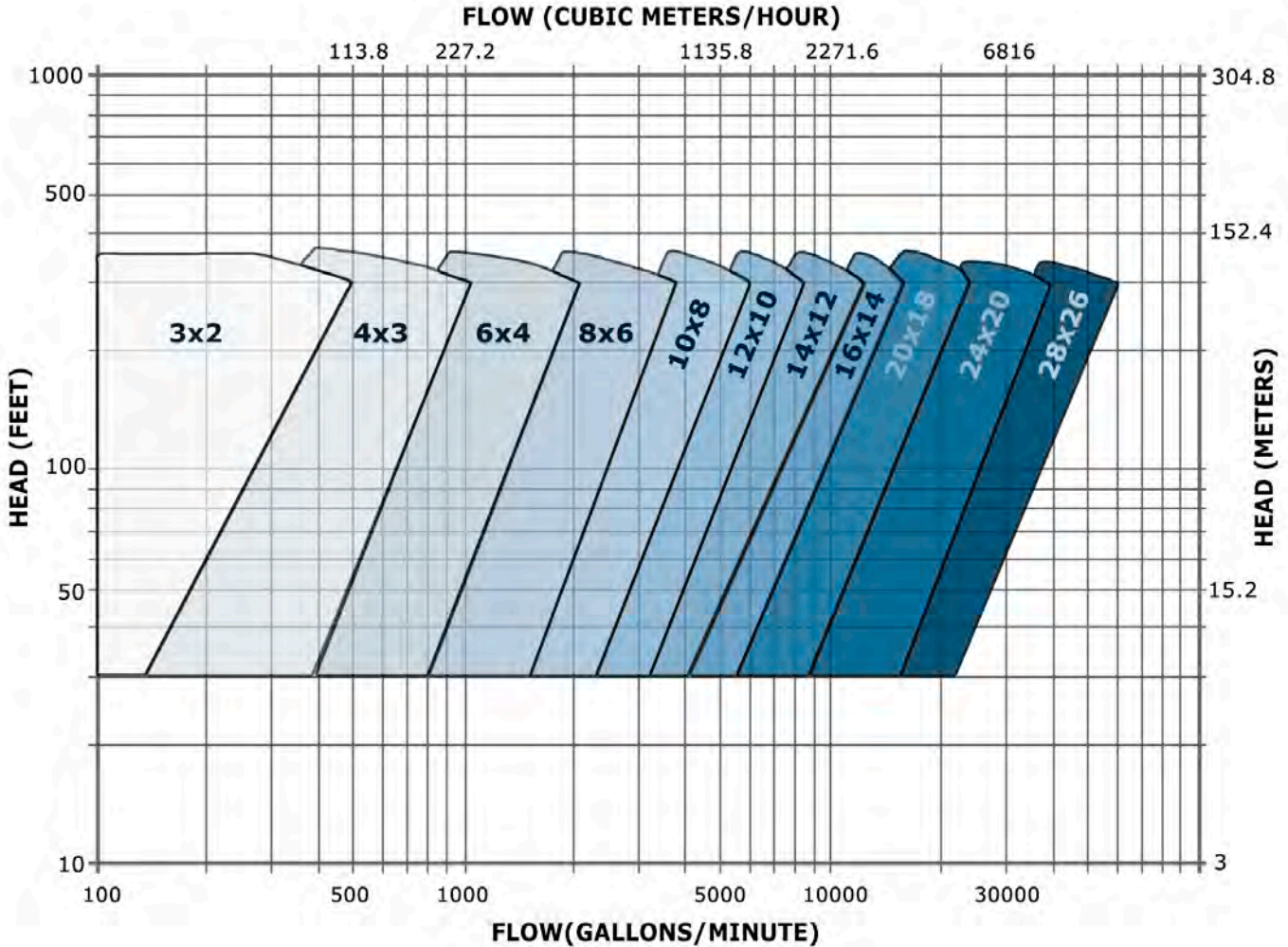

## World-class Service

The Krebs' customer service philosophy is to consistently exceed the expectations of our customers when it comes to providing technical support, processing orders and maintaining parts availability. Starting with the sales process, and extending throughout the life of the supplied process solution, we strive to provide an unmatched, world-class customer experience.

**Tucson, Arizona USA**  
Tel: +1 520 744 8200  
E-mail: krebs@flsmidth.com

**Neusiedl am See, Austria**  
Tel: +43 2167 3345  
krebseurope@flsmidth.com

**Beijing P.R. China**  
Tel: +86-10 8468 9100  
krebschina@flsmidth.com

**Johannesburg, South Africa**  
Tel: +27 (0)10 210 4750  
krebsafrica@flsmidth.com

**Queensland, Australia**  
Tel: +61 7 5519 5700  
krebsaustralia@flsmidth.com

**Sao Paulo, Brasil**  
Tel: +55-15-3416-7400  
krebsbrasil@flsmidth.com

**Chennai, India**  
Tel: +91 44 4748 1000  
krebsindia@flsmidth.com

[www.flsmidthkrebs.com](http://www.flsmidthkrebs.com)

**Western Australia**  
Tel: +61 8 6258 4800  
krebsaustralia@flsmidth.com

**Santiago, Chile**  
Tel: +56 2 2463 8350  
krebschile@flsmidth.com

**Manila, Philippines**  
Tel: +63-2-687-9251  
Krebs-Philippines@flsmidth.com

